

SHELVING

ALÇADOS
ÉTAGÈRE

SHELVING SYSTEM

ALÇADO
SYSTÈME D'ÉTAGÈRES



SHELVING SYSTEM

The modular shelving system is a flexible and evolving system that allows adaptation to different dimensions, configurations and needs. Possibility of having technicals rails with electric rail and fluid chute, or technical core with removable service panels that allows easy replacement or addition of services, as well as quick access to technical connections in maintenance operations.

Shelves with frame securing accessories in vertical riser channels that allow the supporting structure to slide along the plumb for easy adjustment of shelf height, front retention for retention rounded edges for protection and for easy cleaning, frontal and lateral retention to prevent the fall of materials and equipment. They also allow optional incorporation of LED lights into the bottom shelf.

The fixing of the shelving system can be done on the work surface, or on the legs of the workbench, there are versions for walls mounting and central mountings with one or two shelves are presented, the standard shelves being in phenolic compact resin, however optional can be without reinforced glass, or a perforated box format in compact phenolic resins or sheet steel.

ALÇADOS

O sistema de alçado modular para bancadas é um sistema flexível e evolutivo que permite a adaptação a diferentes dimensões, configurações e necessidades. Tem ainda a possibilidade de ter calha técnica com calha eléctrica e calha de fluidos, ou núcleo técnico com painéis de serviços amovíveis que permite a fácil substituição ou adição de serviços, bem como o rápido acesso às ligações técnicas em operações de manutenção.

Prateleiras com acessórios de fixação da estrutura nos canais dos prumos verticais que permitem que a estrutura de suporte deslize ao longo do prumo para fácil regulação em altura da prateleira. São ainda providas de rebordo frontal para retenção, arestas arredondadas para protecção e para facilitar a limpeza, retenção posterior e lateral para prevenir a queda de materiais e equipamentos. Permitem também a incorporação opcional de luzes LED na prateleira inferior.

A fixação do alçado é feita na superfície de trabalho ou nas pernas da bancada. Estão disponíveis as versões para bancadas murais e para bancadas centrais, com uma ou duas prateleiras, sendo que as prateleiras standard são fabricadas em resina de compacto fenólico. No entanto, como opcional, pode ser aplicado vidro aramado, ou em formato de caixa perfurada em compacto de resinas fenólicas ou chapa de aço.

SYSTÈME D'ÉTAGÈRES

Le système d'étagère modulaire est un système flexible et évolutif qui permet de s'adapter à différentes dimensions, configurations et besoins. Possibilité d'avoir une goulotte technique avec goulotte électrique et goulotte de fluide, ou un noyau technique avec des panneaux de service amovibles qui permet de remplacer ou d'ajouter facilement des services, ainsi qu'un accès rapide aux connexions techniques dans les opérations de maintenance.

Étagères avec accessoires de fixation du cadre dans les canaux de colonne montante verticale permettant à la structure de support de glisser le long de montant vertical pour un réglage aisé de la hauteur de l'étagère, bord avant pour la rétention, bords arrondis pour la protection et pour un nettoyage facile éviter la chute de matériaux et d'équipements. Ils permettent également d'incorporer éventuellement des lampes à LED dans l'étagère inférieure.

La fixation de le système d'étagère se fait sur la surface de travail ou sur les pieds du paillasse, les versions pour les paillasses murales et centrales avec une ou deux étagères sont présentées, et les étagères standard sont en résine phénolique compacte, en option, ils peuvent être en verre renforcé, ou en format de boîte perforée dans des résines phénoliques compactes ou des tôles d'acier.

WALL SHELVING SYSTEM

ALÇADO MURAL
SYSTÈME D'ÉTAGÈRE MURALE

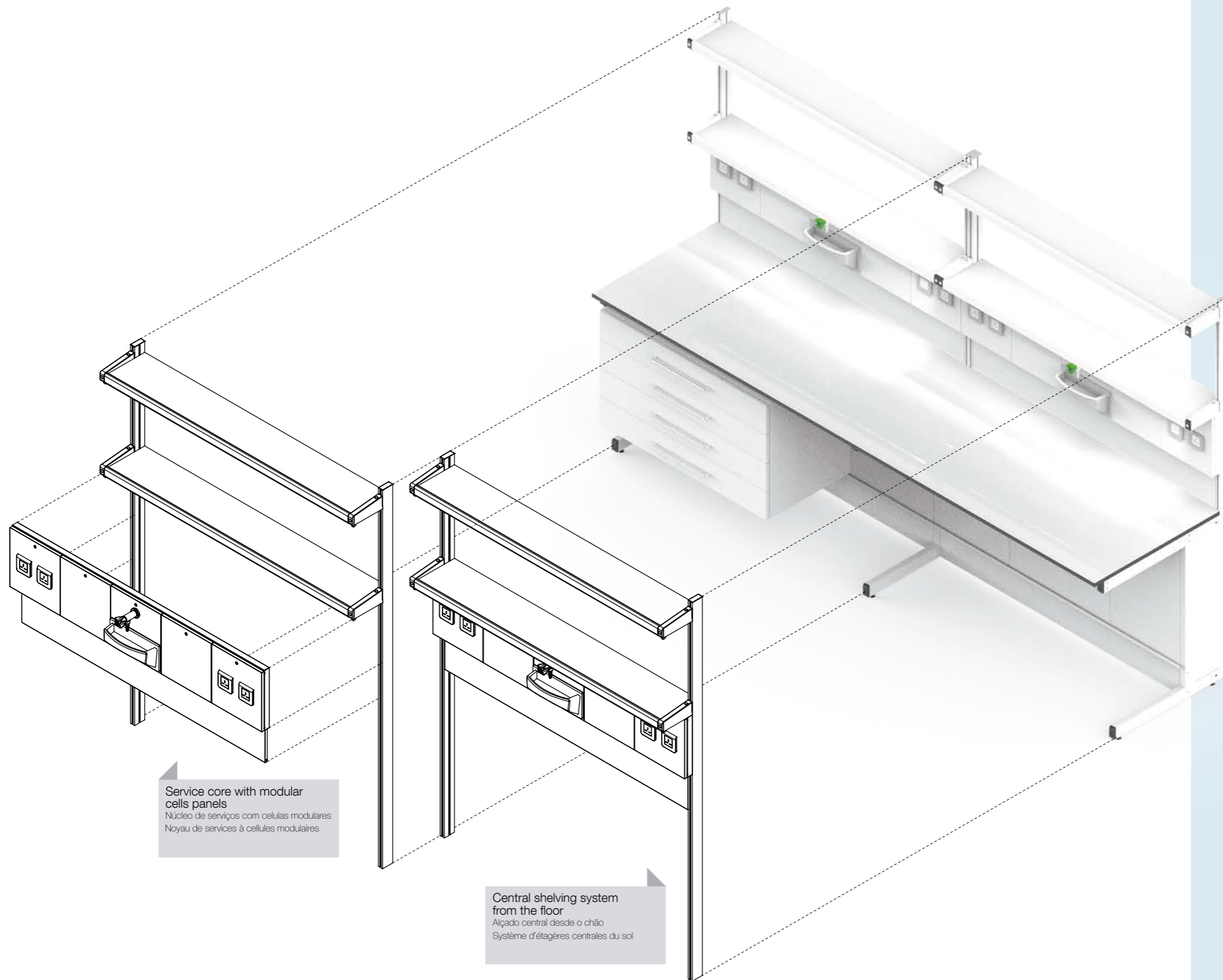

Service core with modular cells panels
Núcleo de serviços com células modulares
Noyau de services à cellules modulaires

Central shelving system from the floor
Alçado central desde o chão
Système d'étagères centrales du sol

WALL SHELVING SYSTEM

The wall shelving system have one or two layers of independent height-adjustable shelves, with the option of installing a white LED light system, with ON / OFF switch. It also present the possibility of incorporating service core with removable panels or rails (electric and fluid). The supply of services can be done from the floor through the bench or the ceiling through the umbilical.

With high mechanical resistance, corrosion resistance, impact and abrasion, high structural and dimensional stability, smooth surfaces of easy cleaning and disinfection, the shelves allow adjustment in height, ensuring that your needs will be met.

A collapsible construction ensures easy transport and installation flexibility, with two aluminum profile uprights, shelf support in powder-coated steel sheet of epoxy-polyester resins, shelves in compact phenolic sheet and cabinets in steel sheet, powder coated with epoxy-polyester resins or in melamine-coated wood.

ALÇADO MURAL

Os alçados murais têm uma ou duas filas de prateleiras independentes ajustáveis em altura, com a opção de instalação de um sistema de luz LED, de cor branca, com interruptor ON/OFF. Apresentam também a possibilidade de incorporar núcleos de serviços com painéis amovíveis ou calhas (elétrica e de fluidos). A alimentação de serviços pode ser feita através da bancada ou pelo teto, através do umbilical.

Com elevada resistência mecânica, resistência à corrosão, ao impacto e abrasão, elevada estabilidade estrutural e dimensional, superfícies lisas de fácil limpeza e desinfecção, as suas prateleiras permitem ajuste em altura, garantindo a satisfação das necessidades dos nossos clientes.

Uma construção desmontável garante a facilidade de transporte e flexibilidade de instalação. São providas ainda de dois prumos em perfil de alumínio, suporte de prateleiras em chapa de aço revestido a pó termoendurecido de resinas epóxi-poliéster, prateleiras em compacto de resinas fenólicas, móveis em chapa de aço revestido a pó termoendurecido de resinas epóxi-poliéster ou em aglomerado revestido a melamina.

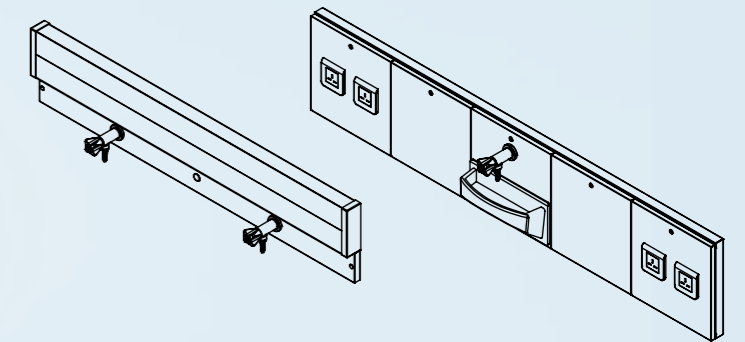

Service rails
Calhas de serviços
Rails des services

Service core with modular cells panels
Núcleo de serviços com células modulares
Noyau de services à cellules modulaires

SYSTÈME D'ÉTAGÈRE MURALE

Les systèmes d'étagères murales ont une ou deux rangées d'étagères indépendantes réglables en hauteur, avec la possibilité d'installer un système d'éclairage à LED blanches avec interrupteur ON / OFF. Ils offrent également la possibilité d'incorporer de noyau de services avec des panneaux ou des rails amovibles (électriques et fluides). L'alimentation des services peut se faire à travers le paillasse ou le plafond à travers l'ombilical.

Avec une résistance mécanique élevée, une résistance à la corrosion, des chocs et à l'abrasion, une stabilité structurelle et dimensionnelle élevée, des surfaces lisses faciles à nettoyer et à désinfecter, vos étagères permettent un réglage en hauteur vous permettant de répondre à vos besoins.

Une construction pliable facilite le transport et la flexibilité d'installation, avec deux montants verticaux profilés en aluminium, support d'étagère en tôle d'acier thermodurcissable en résine époxy-polyester, étagères compactes en résine phénolique, meubles en tôle d'acier revêtement en poudre avec des résines époxy-polyester ou dans des agglomérats revêtus de mélamine.

MATERIALS AND CODIFICATION

MATERIAIS E CODIFICAÇÃO
MATÉRIEL ET CODIFICATION

Wall Upright

Alçado de parede
Montant mural

Wall upright fixed to the worktop
Alçado de parede fixado à superfície de trabalho
Montant mural fixé à la surface de travail

**1 shelf
480mm height**
1 prateleira
480mm de altura
1 étagère
480mm de hauteur

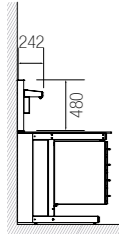

Shelf depth:
242

Profundidade da prateleira:
242

Profondeur de étagère:
242

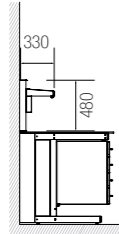

Shelf depth:
330

Profundidade da prateleira:
330

Profondeur de étagère:
330

**2 shelves
800mm height**
2 prateleiras
800mm de altura
2 étagères
800mm de hauteur

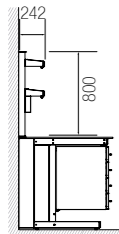

Shelf depth:
242

Profundidade da prateleira:
242

Profondeur de étagère:
242

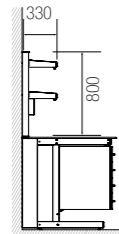

Shelf depth:
330

Profundidade da prateleira:
330

Profondeur de étagère:
330

Wall Writing Station

Posto de escrita mural
Station d'écriture

Wall writing station fixed to the bench legs
Posto de escrita de parede fixo às pernas da bancada
Station d'écriture murale fixé aux pieds de paillasse

Writing stations are designed for a work position at a plane of 750mm height.
Os postos de escrita são projetados para uma posição de trabalho a um plano de 750mm de altura.
Les postes d'écriture sont conçus pour une position de travail sur un plan de 750mm d' hauteur.

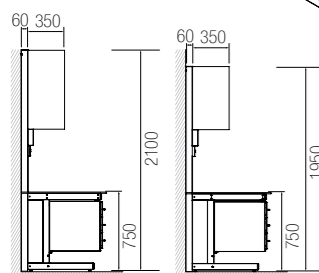
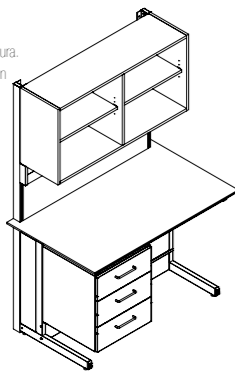

As the name implies the uprights with fixation to the bench legs can only be used in a bench with a 690mm depth leg.

Como o nome indica, os alçados com fixação nas pernas da bancada só podem ser usados numa bancada com uma perna de 690mm de profundidade.

Comme son nom l'indique, les montants avec fixation dans les pieds de paillasse ne peuvent être utilisés que sur une paillasse avec une pied de 690mm de profondeur.

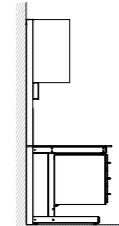

**1 shelf
480mm height**
1 prateleira
480mm de altura
1 étagère
480mm de hauteur

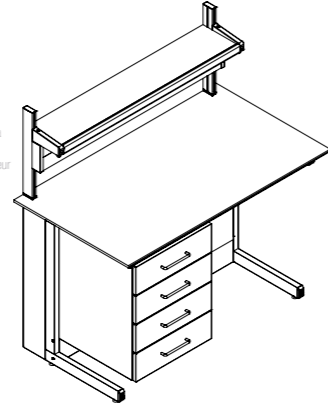

**2 shelves
800mm height**
2 prateleiras
800mm de altura
2 étagères
800mm de hauteur

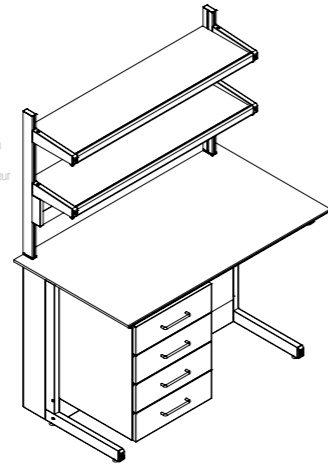

Floor Upright

Alçado de chão
Montant du sol

Wall upright fixed to the bench legs
Alçado de parede fixo às pernas da bancada
Montant mural fixé aux pieds de paillasse

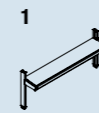
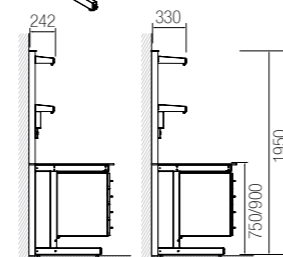
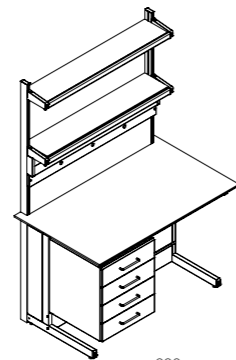

Shelving system without panel, fixed to the worktop.

Alçado sem painéis, fixação à superfície de trabalho.

Système d'étagères sans panneaux, fixé à la surface de travail.

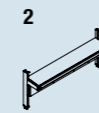

Shelving system with panels, fixed to the worktop.

Alçado com painéis, fixação à superfície de trabalho.

Système d'étagères avec panneaux, fixé à la surface de travail.



Shelving system without panel, fixed to the bench leg.

Alçado sem painéis, fixação à perna da bancada.

Système d'étagère sans panneaux, fixé aux pieds de la paillasse.



Shelving system with panel 300x300, fixed to the bench leg.

Alçado com painéis 300x300, fixação à perna da bancada.

Système d'étagère avec panneau 300x300, fixé aux pieds de la paillasse.



Shelving system with panel 300x160, fixed to the bench leg.

Alçado com painéis 300x160, fixação à perna da bancada.

Système d'étagère avec panneau 300x160, fixé aux pieds de la paillasse.



Isolated writing station without panels.

Posto de escrita isolado sem painéis.

Station d'écriture isolé sans panneaux.



Complementary writing station without panels.

Posto de escrita complementar sem painéis.

Station d'écriture complémentaire sans panneaux.

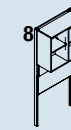

Writing station with panels.

Posto de escrita com painéis.

Station d'écriture avec panneaux.

STEEL SHEET
CHAPA DE AÇO
TÔLE D'ACIER

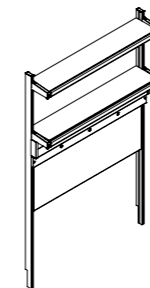
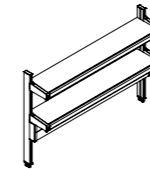
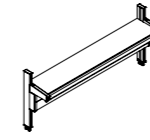

L x W x H*

600x242x480	251-0001	257-0001
900x242x480	251-0002	257-0002
1200x242x480	251-0003	257-0003
1500x242x480	251-0004	257-0004
1800x242x480	251-0005	257-0005
600x330x480	251-0006	257-0006
900x330x480	251-0007	257-0007
1200x330x480	251-0008	257-0008
1500x330x480	251-0009	257-0009
1800x330x480	251-0010	257-0010

600x242x800	251-0011	257-0011
900x242x800	251-0012	257-0012
1200x242x800	251-0013	257-0013
1500x242x800	251-0014	257-0014
1800x242x800	251-0015	257-0015
600x330x800	251-0026	257-0026
900x330x800	251-0027	257-0027
1200x330x800	251-0028	257-0028
1500x330x800	251-0029	257-0029
1800x330x800	251-0030	257-0030

*Length x Width x Height
*Comprimento x Largura x Altura
*Longueur x Largeur x Hauteur

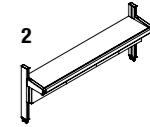
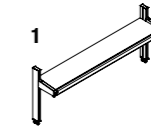

L x W x H (Bh)*

600x242x1950 (750)	252-0001	258-0001	265-0001
900x242x1950 (750)	252-0002	258-0002	265-0002
1200x242x1950 (750)	252-0003	258-0003	265-0003
1500x242x1950 (750)	252-0004	258-0004	265-0004
1800x242x1950 (750)	252-0005	258-0005	265-0005
600x242x1950 (900)	252-0006	258-0006	265-0006
900x242x1950 (900)	252-0007	258-0007	265-0007
1200x242x1950 (900)	252-0008	258-0008	265-0008
1500x242x1950 (900)	252-0009	258-0009	265-0009
1800x242x1950 (900)	252-0010	258-0010	265-0010

*Length x Width x Height (Bench height)
*Comprimento x Largura x Altura (altura de bancada)
*Longueur x Largeur x Hauteur (Hauteur du paillasse)

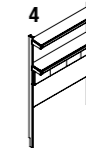
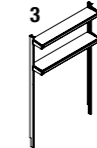

STEEL SHEET (CABINETS)
CHAPA DE AÇO (ARMÁRIOS)
TÔLE D'ACIER (ARMOIRES)



MELAMINE (CABINETS)
MELAMINA (ARMÁRIOS)
MÉLAMINE (ARMOIRES)

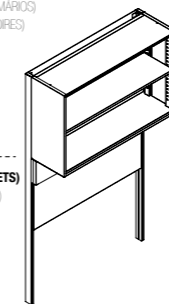

L x W x H*

900x410x1950	256-0011	255-0011	258-1002
1200x410x1950	256-0012	255-0012	258-1003
900x410x2100	256-0015	255-0015	258-1007
1200x410x2100	256-0016	255-0016	258-1008

900x410x1950	256-0001	255-0001
1200x410x1950	256-0002	255-0002
900x410x2100	256-0005	255-0005
1200x410x2100	256-0006	255-0006

*Length x Width x Height
*Comprimento x Largura x Altura
*Longueur x Largeur x Hauteur

CENTRAL SHELVING SYSTEM

ALÇADO CENTRAL
SYSTÈME D'ÉTAGÈRES CENTRALES

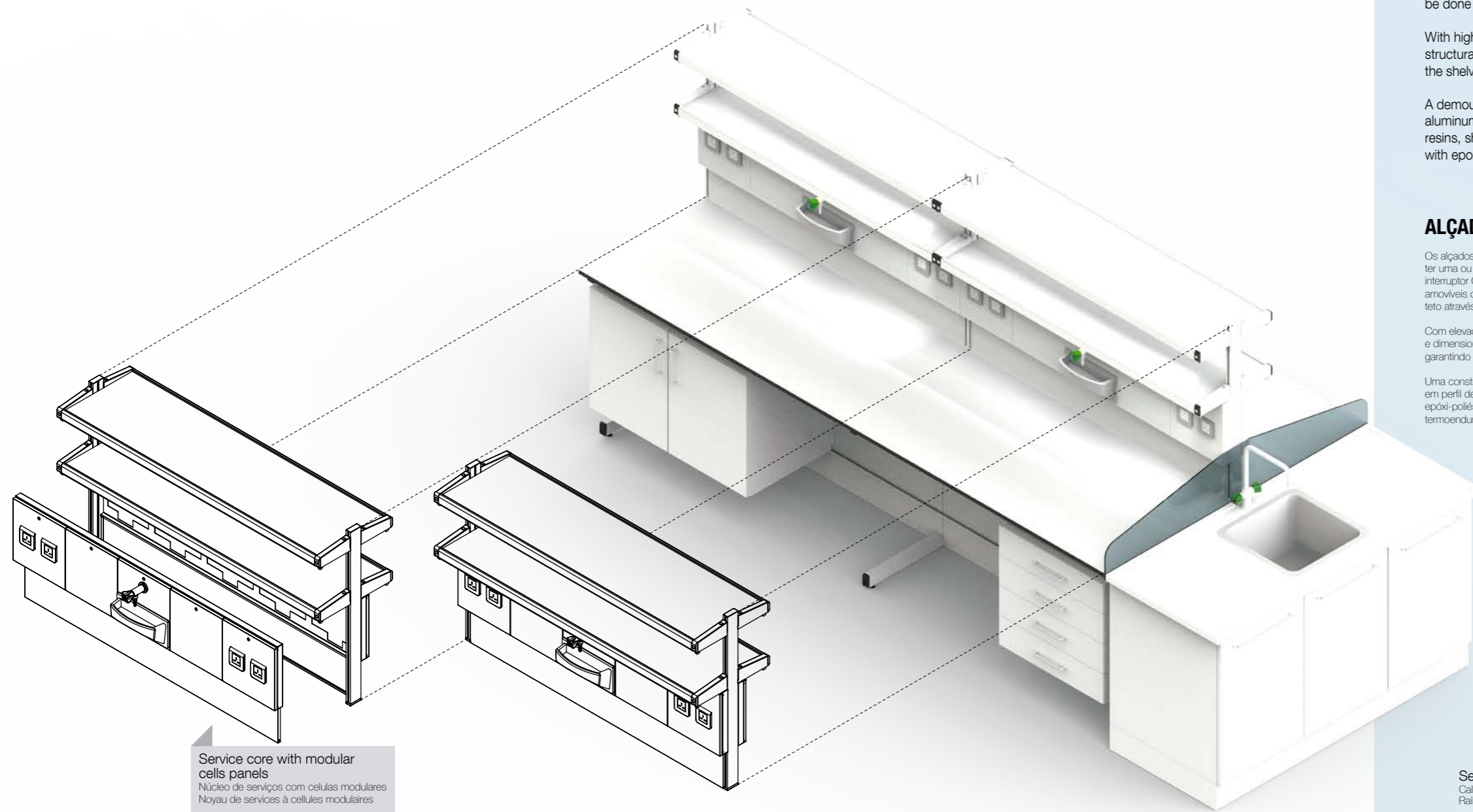

Service core with modular cells panels
Núcleo de serviços com células modulares
Noyau de services à cellules modulaires

Central shelving system over worktop
Alçado central sobre tampo
Système d'étagères centrales sur le plan de travail

CENTRAL SHELVING SYSTEM

The central shelving system has one or two independent height-adjustable shelves in each layer, and it can have one or two layers, with the option of installing a white LED light system, with ON / OFF switch. It also presents the possibility of incorporating service core with removable panels or rails (electric and fluid). The supply of services can be done from the floor through the bench or the ceiling through the umbilical.

With high mechanical resistance, corrosion resistance, impact and abrasion, high structural and dimensional stability, smooth surfaces of easy cleaning and disinfection, the shelves allow adjustment in height, ensuring that your needs will be met.

A demountable construction ensures easy transport and installation flexibility, with two aluminum profile uprights, shelf support in powder-coated steel sheet of epoxy-polyester resins, shelves in compact phenolic sheet and cabinets in steel sheet, powder coated with epoxy-polyester resins or in melamine-coated wood.

ALÇADO CENTRAL

Os alçados centrais têm uma ou duas prateleiras independentes ajustáveis em altura em cada camada, e pode ter uma ou duas camadas, com a opção de instalação de um sistema de luz LED, de cor branca, com interruptor ON/OFF. Apresentam também a possibilidade de incorporar núcleos de serviços com painéis amovíveis ou calhas (elétrica e de fluidos). A alimentação de serviços pode ser feita através da bancada ou pelo teto através do umbilical.

Com elevada resistência mecânica, resistência à corrosão, ao impacto e abrasão, elevada estabilidade estrutural e dimensional, superfícies lisas de fácil limpeza e desinfeção, as suas prateleiras permitem ajuste em altura, garantindo que as suas necessidades serão satisfeitas.

Uma construção desmontável garante a facilidade de transporte e flexibilidade de instalação, com dois prumos em perfil de alumínio, suporte de prateleiras em chapa de aço revestido a pó termoendurecido de resinas epóxi-poliéster, prateleiras em compacto de resinas fenólicas, móveis em chapa de aço revestido a pó termoendurecido de resinas epóxi-poliéster ou em aglomerado revestido a melamina.

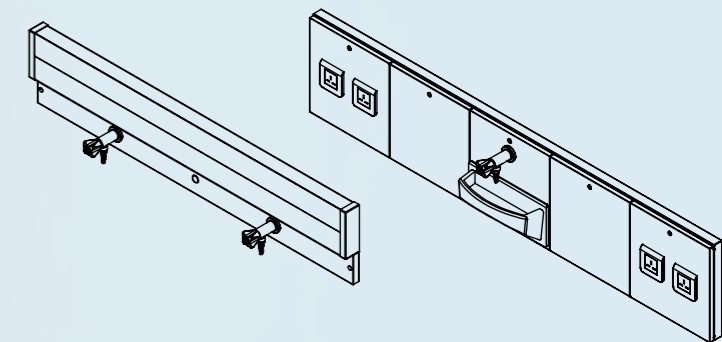

Service rails
Calhas de serviços
Rails des services

Service core with modular cells panels
Núcleo de serviços com células modulares
Noyau de services à cellules modulaires

SYSTÈME D'ÉTAGÈRE CENTRALE

Les systèmes d'étagères centrales ont une ou deux étagères réglables en hauteur indépendantes de chaque couche et peuvent avoir une ou deux couches, avec la possibilité d'installer un système d'éclairage en LED blanches avec interrupteur ON / OFF. Ils offrent également la possibilité d'incorporer de noyau de services avec des panneaux ou des rails amovibles (électriques et fluides). L'alimentation des services peut se faire à travers le paillasson ou le plafond à travers l'ombilical.

Avec une résistance mécanique élevée, une résistance à la corrosion, des chocs et à l'abrasion, une stabilité structurelle et dimensionnelle élevée, des surfaces lisses faciles à nettoyer et à désinfecter, vos étagères permettent un réglage en hauteur vous permettant de répondre à vos besoins.

Une construction démontable facilite le transport et la flexibilité d'installation, avec deux montants verticaux profilés en aluminium, support d'étagère en tôle d'acier thermocroissable en résine époxy-polyester, étagères compactes en résine phénolique, meubles en tôle d'acier revêtement en poudre avec des résines époxy-polyester ou dans des agglomérats revêtus de mélamine.

MATERIALS AND CODIFICATION

MATERIAIS E CODIFICAÇÃO
MATÉRIEL ET CODIFICATION

Central Upright

Alçado central
Montant central

Central upright fixed to the worktop
Alçado central fixado à superfície de trabalho
Montant central fixé à la surface de travail

1 shelf
480mm height
1 prateleira
480mm de altura
1 étagère
480mm de hauteur

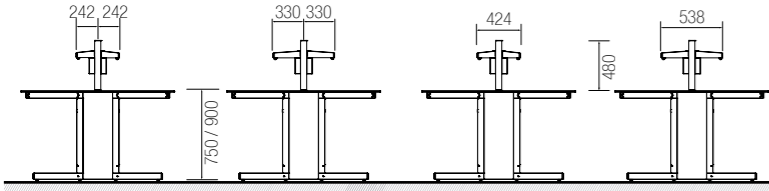

Shelf depth:	Shelf depth:	Shelf depth:	Shelf depth:
242 x 2	269 x 2	424	538
Profundidade da prateleira: 242 x 2	Profundidade da prateleira: 269 x 2	Profundidade da prateleira: 424	Profundidade da prateleira: 538
Profondeur d'étagère: 242 x 2	Profondeur d'étagère: 269 x 2	Profondeur d'étagère: 424	Profondeur d'étagère: 538

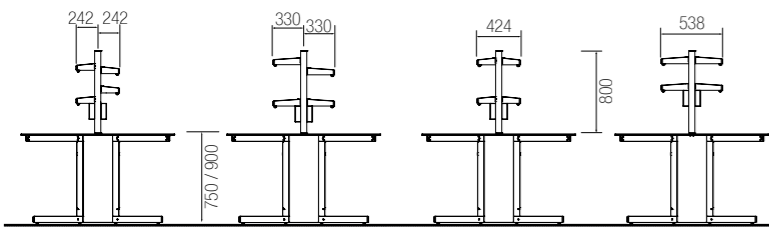

2 shelves
800mm height
2 prateleiras
800mm de altura
2 étagères
800mm de hauteur

1 shelf
480mm height
1 prateleira
480mm de altura
1 étagère
480mm de hauteur

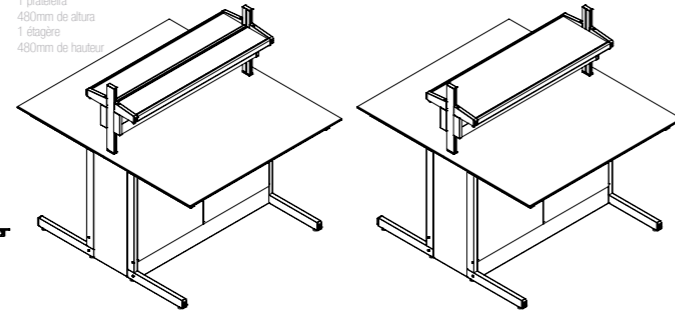

2 shelves
800mm height
2 prateleiras
800mm de altura
2 étagères
800mm de hauteur

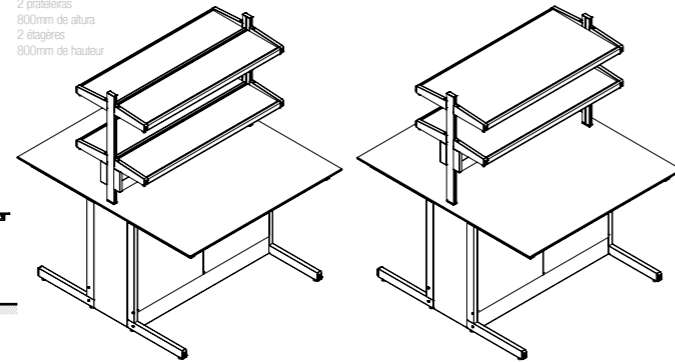

Central Writing Station

Posto de escrita central
Station d'écriture centrale

Central writing station fixed to the bench legs
Posto de escrita central fixo às pernas da bancada
Station d'écriture centrale fixé aux pieds de pailasse

Writing stations are designed for a work position at a plane of 750mm height.
Os postos de escrita são projetados para uma posição de trabalho a um plano de 750mm de altura.
Les stations d'écriture sont conçues pour une position de travail sur un plan de 750mm d hauteur.

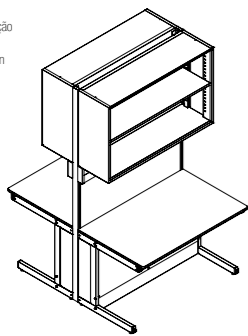

As the name implies, the uprights with fixation to the bench legs can only be used in a bench with a 690mm depth leg.

Como o nome indica, os alçados com fixação nas pernas da bancada só podem ser usados numa bancada com uma perna de 690mm de profundidade.

Comme son nom l'indique, les montants avec fixation dans les pieds de pailasse ne peuvent être utilisés que sur une pailasse avec une pied de 690mm de profondeur.

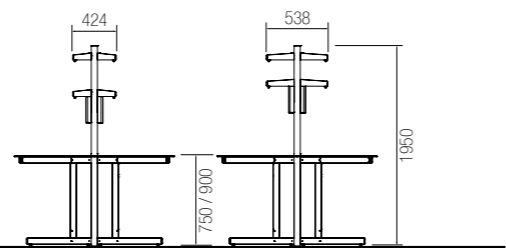
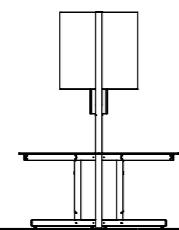
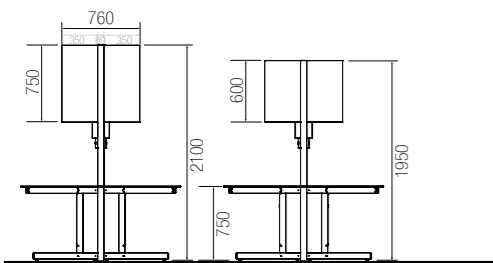

Floor Upright

Alçado de chão
Support du sol

Central upright fixed to the bench legs
Alçado central fixo às pernas da bancada
Montant central fixé aux pieds de pailasse

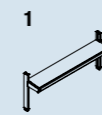
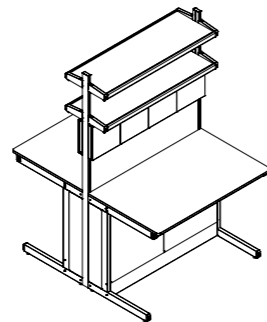

Shelving system without panel, fixed to the worktop.

Alçado sem painéis, fixação à superfície de trabalho.

Système d'étagères sans panneaux, fixé à la surface de travail.

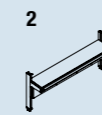

Shelving system with panels, fixed to the worktop.

Alçado com painéis, fixação à superfície de trabalho.

Système d'étagère avec panneaux, fixé à la surface de travail.



Shelving system without panel, fixed to the bench leg.

Alçado sem painéis, fixação à perna da bancada.

Système d'étagère sans panneaux, fixé aux pieds de la pailasse.



Shelving system with panel 300x300, fixed to the bench leg.

Alçado com painéis 300x300, fixação à perna da bancada.

Système d'étagère avec panneau 300x300, fixé aux pieds de la pailasse.



Shelving system with panel 300x160, fixed to the bench leg.

Alçado com painéis 300x160, fixação à perna da bancada.

Système d'étagère avec panneau 300x160, fixé aux pieds de la pailasse.



Isolated writing station without panels.

Posto de escrita isolado sem painéis.

Station d'écriture isolé sans panneaux.



Complementar writing station without panels.

Posto de escrita complementar sem painéis.

Station d'écriture complémentaire sans panneaux.

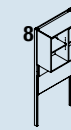

Writing station with panels.

Posto de escrita com painéis.

Station d'écriture avec panneaux.

STEEL SHEET

CHAPA DE AÇO

TÔLE D'ACIER

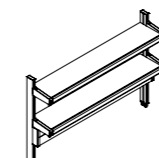
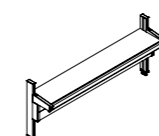

L x W x H*

L x W x H*	251-0016	257-0016
600x424x480	251-0016	257-0016
900x424x480	251-0017	257-0017
1200x424x480	251-0018	257-0018
1500x424x480	251-0019	257-0019
1800x424x480	251-0020	257-0020
600x538x480	251-0316	257-0316
900x538x480	251-0317	257-0317
1200x538x480	251-0318	257-0318
1500x538x480	251-0319	257-0319
1800x538x480	251-0320	257-0320

L x W x H*	251-0021	257-0021
600x424x800	251-0021	257-0021
900x424x800	251-0022	257-0022
1200x424x800	251-0023	257-0023
1500x424x800	251-0024	257-0024
1800x424x800	251-0025	257-0025
600x538x800	251-0321	257-0321
900x538x800	251-0322	257-0322
1200x538x800	251-0323	257-0323
1500x538x800	251-0324	257-0324
1800x538x800	251-0325	257-0325

*Length x Width x Height
*Comprimento x Largura x Altura
*Longueur x Largeur x Hauteur

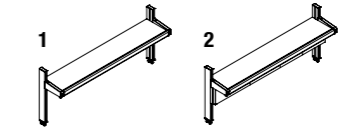

L x W x H*	251-0116	257-0116
600x242(*2)x480	251-0116	257-0116
900x242(*2)x480	251-0117	257-0117
1200x242(*2)x480	251-0118	257-0118
1500x242(*2)x480	251-0119	257-0119
1800x242(*2)x480	251-0120	257-0120
600x330(*2)x480	251-0216	257-0216
900x330(*2)x480	251-0217	257-0217
1200x330(*2)x480	251-0218	257-0218
1500x330(*2)x480	251-0219	257-0219
1800x330(*2)x480	251-0220	257-0220

L x W x H*	251-0121	257-0121
600x242(*2)x800	251-0121	257-0121
900x242(*2)x800	251-0122	257-0122
1200x242(*2)x800	251-0123	257-0123
1500x242(*2)x800	251-0124	257-0124
1800x242(*2)x800	251-0125	257-0125
600x330(*2)x800	251-0221	257-0221
900x330(*2)x800	251-0222	257-0222
1200x330(*2)x800	251-0223	257-0223
1500x330(*2)x800	251-0224	257-0224
1800x330(*2)x800	251-0225	257-0225

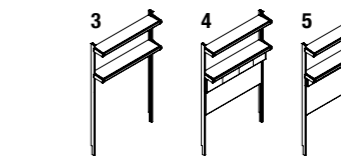

L x W x H (Bh)*

L x W x H (Bh)*	252-0011	258-0011	265-0011
600x424x1950 (750)	252-0011	258-0011	265-0011
900x424x1950 (750)	252-0012	258-0012	265-0012
1200x424x1950 (750)	252-0013	258-0013	265-0013
1500x424x1950 (750)	252-0014	258-0014	265-0014
1800x424x1950 (750)	252-0015	258-0015	265-0015
600x424x1950 (900)	252-0111	258-0111	265-0111
900x424x1950 (900)	252-0112	258-0112	265-0112
1200x424x1950 (900)	252-0113	258-0113	265-0113
1500x424x1950 (900)	252-0114	258-0114	265-0114
1800x424x1950 (900)	252-0115	258-0115	265-0115

*Length x Width x Height (Bench height)
*Comprimento x Largura x Altura (Altura de bancada)
*Longueur x Largeur x Hauteur (Hauteur de pailasse)

STEEL SHEET (CABINETS)

CHAPA DE AÇO (ARMÁRIOS)

TÔLE D'ACIER (ARMOIRES)



MELAMINE (CABINETS)

MELAMINA (ARMÁRIOS)

MÉLAMINE (ARMOIRES)



L x W x H*

L x W x H*	256-0013	255-0013	258-1112
900x760x1950	256-0013	255-0013	258-1112
1200x760x1950	256-0014	255-0014	258-1113
900x760x2100	256-0017	255-0017	258-1012
1200x760x2100	256-0018	255-0018	258-1013

L x W x H*	256-0003	255-0003
900x760x1950	256-0003	255-0003
1200x760x1950	256-0004	255-0004
900x760x2100	256-0007	255-0007
1200x760x2100	256-0008	255-0008

*Length x Width x Height
*Comprimento x Largura x Altura
*Longueur x Largeur x Hauteur

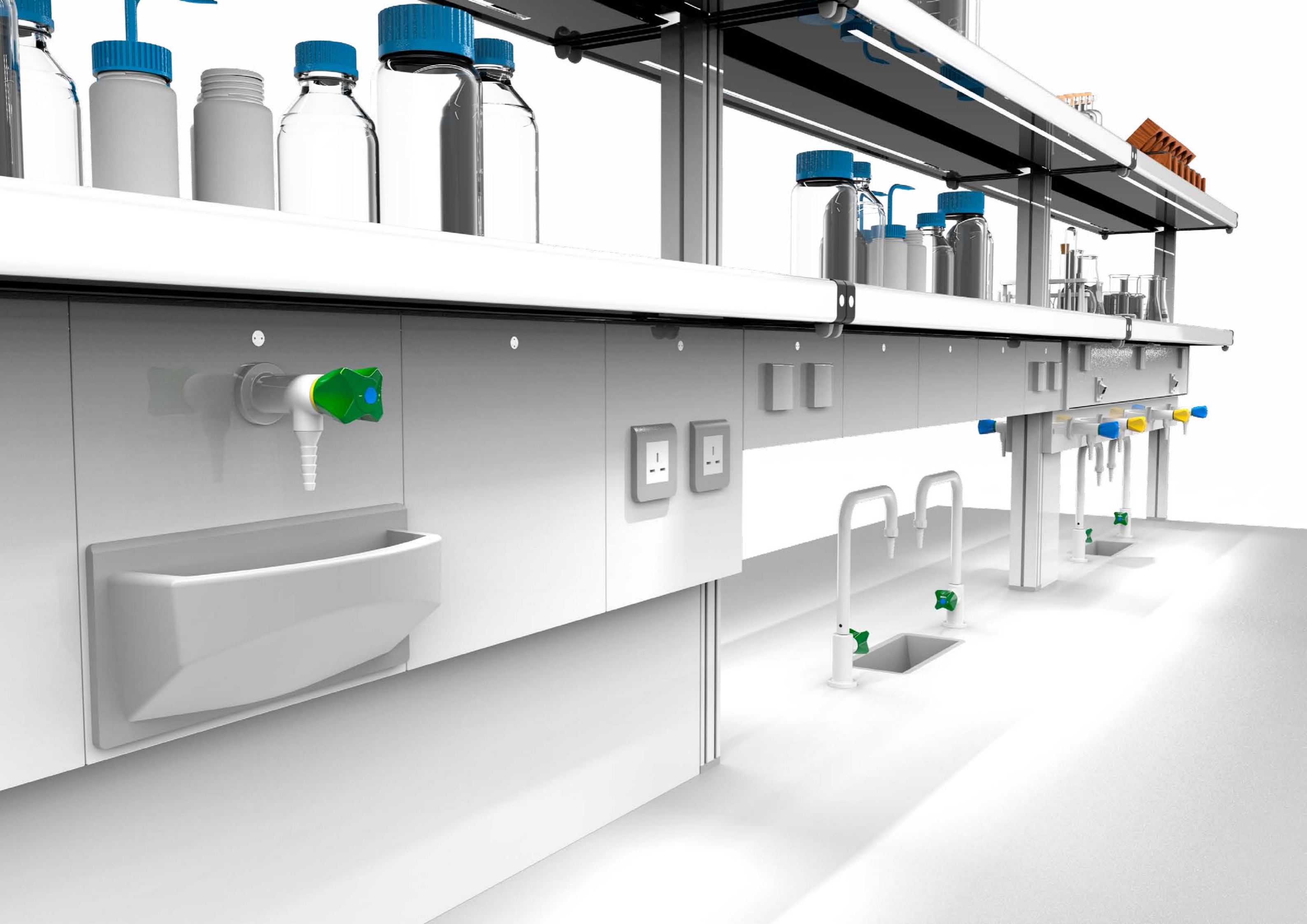

SHELVING & SERVICES

PRATELEIRAS E SERVIÇOS
ÉTAGÈRES ET SERVICES



SHELVING SYSTEM

The modular shelving system is a flexible and evolving system that allows adaptation to different dimensions, configurations and needs. A with the possibility of having technicals rails with electric rail and fluid chute, or technical core with removable service panels that allows easy replacement or addition of services, as well as quick access to technical connections in maintenance operations.

Shelves with frame securing accessories in vertical riser channels that allow the supporting structure to slide along the plumb for easy adjustment of shelf height, front retention for retention rounded edges for protection and for easy cleaning, frontal and lateral retention to prevent the fall of materials and equipment. They also allow optional incorporation of LED lights into the bottom shelf.

The fixation of the shelving system can be done on the work surface, or on the legs of the workbench, there are versions for walls mounting and central mountings with one or two shelves are presented, the standard shelves being in phenolic compact resin, however optional can be without reinforced glass, or a perforated box format in compact phenolic resins or sheet steel.

ALÇADOS

O sistema de alçado modular para bancadas é um sistema flexível e evolutivo que permite a adaptação a diferentes dimensões, configurações e necessidades. Com a possibilidade de ter calha técnica com calha eléctrica e calha de fluidos, ou núcleo técnico com painéis de serviços amovíveis que permite a fácil substituição ou adição de serviços, bem como o rápido acesso às ligações técnicas em operações de manutenção.

Prateleiras com acessórios de fixação da estrutura nos canais dos prumos verticais que permitem que a estrutura de suporte deslize ao longo do prumo para fácil regulação da altura da prateleira, rebordo frontal para retenção, com arestas arredondadas para protecção e para facilitar a limpeza, retenção posterior e lateral para prevenir a queda de materiais e equipamentos. Permitem também a incorporação opcional de luzes LED na prateleira inferior.

A fixação do alçado é feita na superfície de trabalho, ou nas pernas da bancada, são apresentadas as versões para bancadas murais e centrais, com uma ou duas prateleiras, sendo as prateleiras standard em resina de compacto fenólico, no entanto como opcionais podem ser em vidro armado, ou em formato de caixa perfurada em compacto de resinas fenólicas ou chapa de aço.

SYSTÈME D'ÉTAGÈRES

Le système d'étagère modulaire est un système flexible et évolutif qui permet de s'adapter à différentes dimensions, configurations et besoins. Avec la possibilité d'avoir une goulotte technique avec rail électrique et goulotte de fluide, ou un noyau technique avec des panneaux de service amovibles qui permet un remplacement ou une addition facile des services, ainsi qu'un accès rapide aux connexions techniques dans les opérations de maintenance.

Étagères avec accessoires de fixation du cadre dans les canaux de colonne montante verticale permettant à la structure de support de glisser le long de montant vertical pour un réglage aisé de la hauteur de l'étagère, bord avant pour la rétention, bords arrondis pour la protection et pour un nettoyage facile éviter la chute de matériaux et d'équipements. Ils permettent également d'incorporer éventuellement des lampes à LED dans la étagère inférieure.

La fixation de le système d'étagère se fait sur la surface de travail ou sur les pieds du paillasse, les versions pour les paillasses muraux et centraux avec une ou deux étagères sont présentées, et les étagères standard sont en résine phénolique compacte, en option, ils peuvent être en verre renforcé, ou en format de boîte perforée dans des résines phénoliques compactes ou des tôles d'acier.

SERVICE CORE

NÚCLEO DE SERVIÇOS
NOYAU DE SERVICES

Panels

Painéis
Panneaux

Main component in the core, integrates the services for the benches
Componente principal no núcleo, integra os serviços para as bancadas
Composant principal dans le noyau, intègre les services pour les paillasses

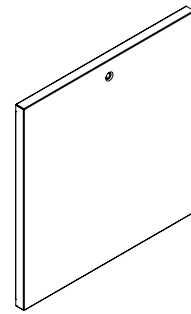

300 x 310

Typology
Tipologia
Typologie

Cod. **260-5001**

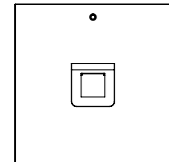

Cod. **260-5002**

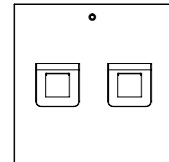

Cod. **260-5003**

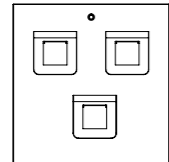

Cod. **260-5004**

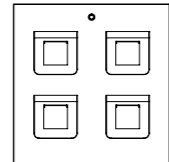

Cod. **260-5005**

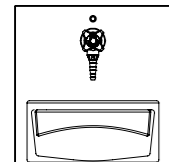

Cod. **260-5009**

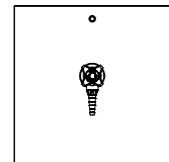

Cod. **260-5006**

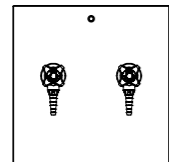

Cod. **260-5007**

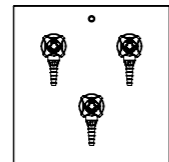

Cod. **260-5008**

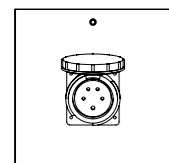

Cod. **260-5010**

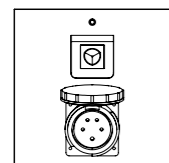

Cod. **260-5011**

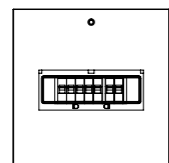

Cod. **260-5012**

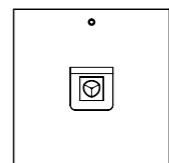

Cod. **260-5013**

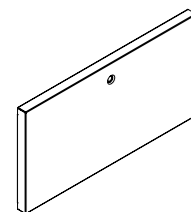

300 x 160

Typology
Tipologia
Typologie

Cod. **260-5101**

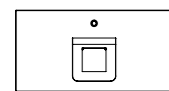

Cod. **260-5102**

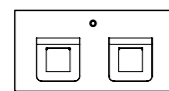

Cod. **260-5103**

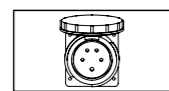

Cod. **260-5110**

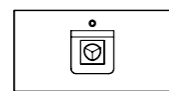

Cod. **260-5113**

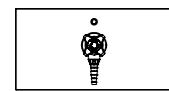

Cod. **260-5106**

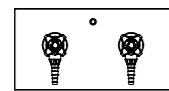

Cod. **260-5107**

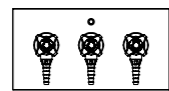

Cod. **260-5108**

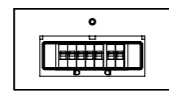

Cod. **260-5101**

Legend of Typology

Legenda de Tipologia
Légende de la typologie



Single phase electrical outlet, or data plug
Tomada eléctrica monofásica ou tomada de dados
Prise électrique monophasée ou prise de données



Valve
Válvula



Triple phase electrical plug
Tomada eléctrica trifásica
Prise électrique triphasée



Cupsink
Piaeta
Évier



Emergency shut-off button
Botão de emergência
Bouton d'urgence



Electrical Circuit Breakers
Disjuntores eléctricos
Disjoncteurs électriques

Services supply, such as electric outlets, data/voice plugs, gases and water. This panels have been developed by INDUSTRIAL LABORUM IBÉRICA, to innovate in technical services. The panels system is composed by a set of modular panels that, while maintaining the same cold roled steel plate allows a safe and easy covering of the services.

Fornecimento de serviços como tomadas eléctricas, tomadas de dados / voz, gases e água. Estes painéis foram desenvolvidos pela INDUSTRIAL LABORUM IBÉRICA, para inovar em serviços técnicos. O sistema de painéis é composto por um conjunto de painéis que, mantém o mesmo aço laminado a frio e que permite uma cobertura mais segura e fácil dos serviços.

Fourniture de services, tels que les prises électriques, les prises de données / voix, le gaz et l'eau. Ces panneaux ont été développés par INDUSTRIAL LABORUM IBÉRICA, pour innover dans les services techniques. Le système de panneaux est composé en un ensemble de panneaux qui maintiennent le même acier laminé à froid et permettent une couverture plus sécurisée et plus facile des services.

300 x 310

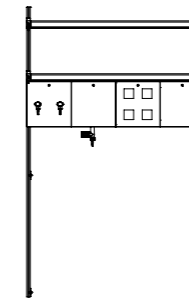

300 x 160

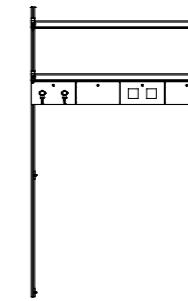

The panels can have 2 dimensions, 300mm length and 310mm or 160mm height
Os painéis podem ter 2 dimensões, 300mm de comprimento e 310mm ou 160mm de altura
Les panneaux peuvent être 2 dimensions, 300mm de longueur et 310mm ou 160mm de hauteur

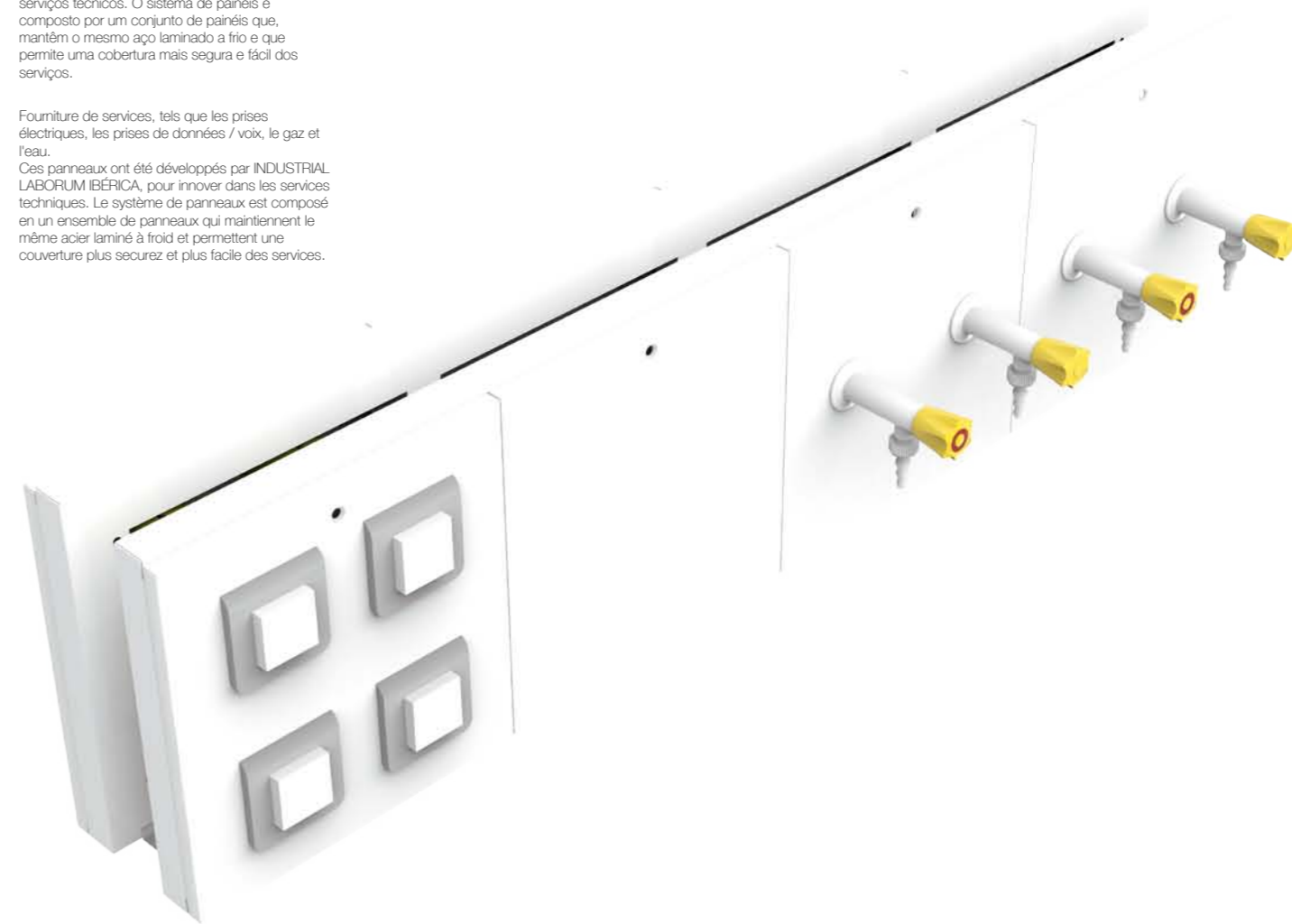

MATERIALS AND CODIFICATION

MATERIAIS E CODIFICAÇÃO MATÉRIEL ET CODIFICATION

Shelf Prateleira Étagère

Materials and typologies of the shelves
Tipologias e material das prateleiras
Types et matériaux des étagères

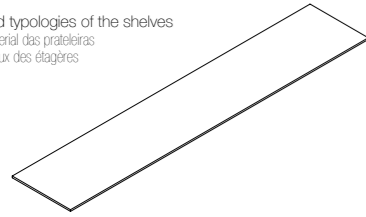

Standard

Compact laminate
Compacto fenólico
Phénolique compact

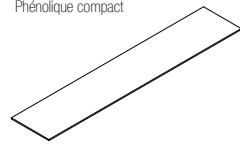

Cod. **261-0000**

Optional | Opcional | Optionnel

Wire reinforced glass
Vidro aramado
Verre de fil

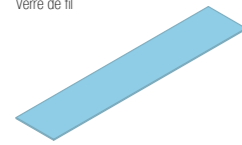

Cod. **261-1000**

Standard

Compact laminate box
Caixa em compacto fenólico
Boîtier en phénolique compact



Cod. **261-2000**

Optional | Opcional | Optionnel

Compact laminate perforated box
Caixa perfurada em compacto fenólico
Boîtier perforé en phénolique compact

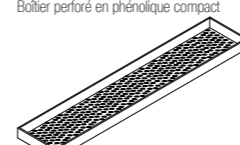

Cod. **261-3000**

Shelf Prateleira Étagère

Upper cabinets for the upright
Módulos superiores para alçado
Modules supérieurs pour le montant

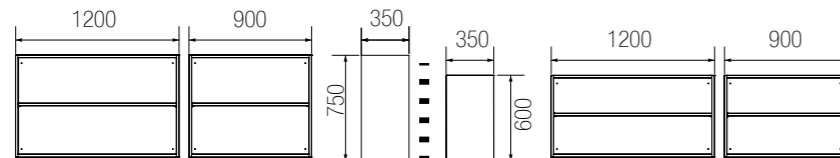

MELAMINE MELAMINA MÉLAMINE

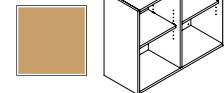

254-0006

254-0005

254-0004

254-0003

STEEL SHEET CHAPA DE AÇO FEUILLE D'ACIER

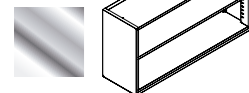

254-0008

254-0007

254-0002

254-0001

LED light Luz LED Lumière LED

Optional LED light system incorporated in the shelf
Sistema de luz LED opcional incorporado na prateleira
Système d'éclairage Optionnel LED incorporé dans l'étagère

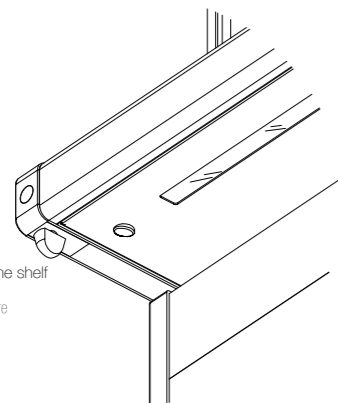

Optional | Opcional | Optionnel

Warm Light
Luz Quente
Lumière Chaude

Cod. **891-5001**

Cod. **891-5002**

Cod. **891-5003**

Cod. **891-5004**

Optional Loox | Opcional Loox | Optionnel Loox

White Light
Luz Branca
Lumière blanche

Cod. **891-5011**

Cod. **891-5012**

Cod. **891-5013**

Cod. **891-5014**

Service rail

Calha de serviços
Rail de services

Other systems
Outros sistemas de serviços
Autres systèmes de service

If there's no need for the services panels but is still needed electric services, fluid and gases services, Industrial Laborum Ibérica has other options.

PVC gutters for the electric and data services, a fluid cap for gases and fluids. We also present cover caps for the worktops and an optional front cover panels.

Se não houver necessidade de painéis de serviços, mas são necessários serviços elétricos, fluidos e de gases, a Industrial Laborum Ibérica possui outras opções. Existem ainda soluções para calhas em PVC para serviços de dados e elétricos, tampa de fluido para gases e fluidos e também apresentamos perfis de remate de superfície de trabalho bem como painéis de remate frontal opcionais.

S'il n'y a pas besoin de panneaux de service, mais que des services d'électricité, de fluides et de gaz sont nécessaires, l'Industrial Laborum Ibérica a d'autres options. Rails en PVC pour les services de données et électriques. Un bouchon de fluide pour les gaz et les fluides et nous avons également des profils de finition de surface ainsi que des panneaux d'extrémité avant optionnelles.

Fluids cap

Panel de fluidos
Panneau de fluide

Panel to house the fluids/data services
Panel para alçar os serviços de fluidos/dados
Panel pour héberger des services de fluides / données

Shelf Length

Comprimento de Prateleira
Longueur d'Étagère

600 Cod. **263-1001**

900 Cod. **263-1002**

1200 Cod. **263-1003**

1500 Cod. **263-1004**

1800 Cod. **263-1005**

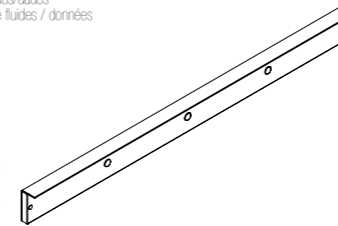

Electrical / data rail

Calha de serviços elétricos / dados
Rail de service électrique / données

Gutter to house electrical services made in PVC
Calha para alçar os serviços elétricos feita em PVC
Rail pour abriter les services électriques en PVC

Shelf Length

Comprimento de Prateleira

Longueur d'Étagère

600 Cod. **263-3101**

900 Cod. **263-3102**

1200 Cod. **263-3103**

1500 Cod. **263-3104**

1800 Cod. **263-3105**

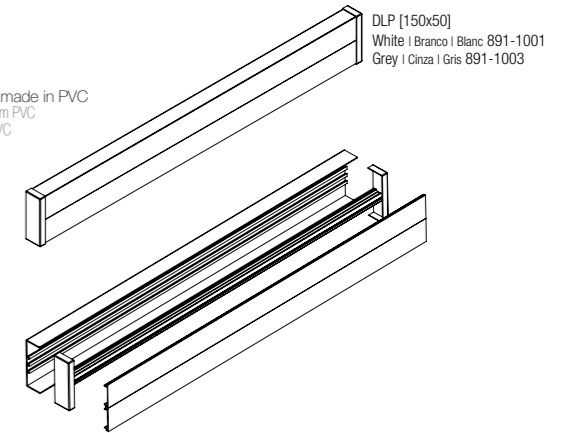

DLP [150x50]
White | Branco | Blanc 891-1001
Grey | Cinza | Gris 891-1003

Frontal cover panel for the upright
Panel de remate frontal para alçados
Panneau de couverture frontal pour le montant

Capping Profile for worktops in PVC
Perfil de remate de tampos em PVC
Profil de recouvrement pour les plans de travail en PVC

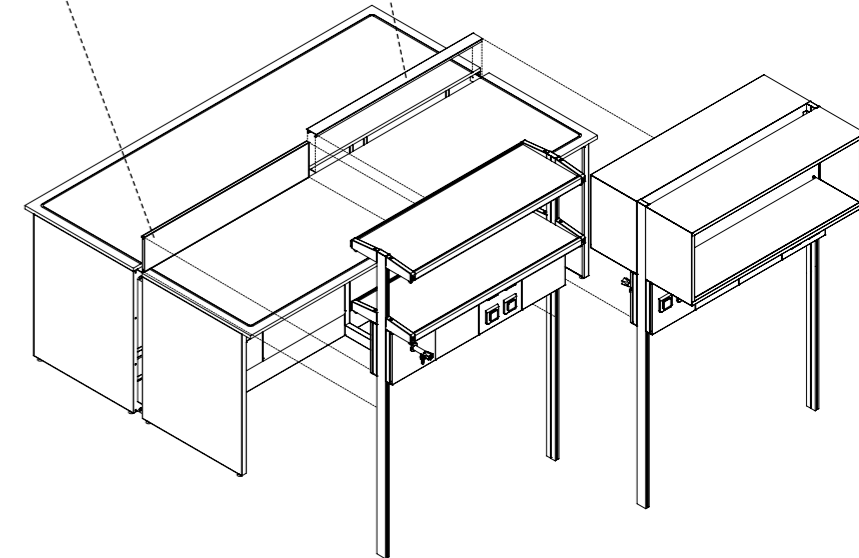

Caps

Painéis
Panneaux

Capping Profile for worktops in PVC
Perfil de remate de tampos em PVC
Profil de recouvrement pour les plans de travail en PVC

Shelf Length
Comprimento da Prateleira
Longueur d'Étagère

600 Cod. **260-0021**

900 Cod. **260-0022**

1200 Cod. **260-0023**

1500 Cod. **260-0024**

1800 Cod. **260-0025**

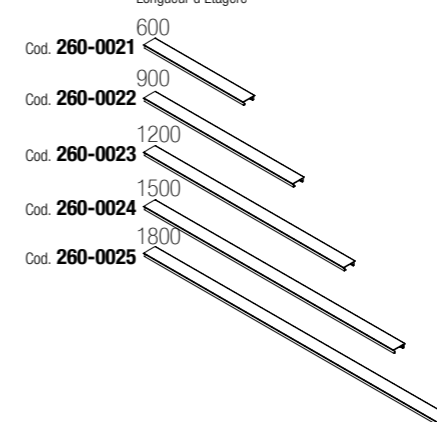

Cover panel

Panel de remate
Panneau de couverture

Frontal cover panel for the upright
Panel de remate frontal para alçados
Panneau de couverture frontal pour le montant

Shelf Length
Comprimento de Prateleira
Longueur d'Étagère

600

900

1200

1500

1800

Writing post
Posto de escrita
Poste d'écriture

520

Self Upright
Alçado
Montant

420

Self Upright
Alçado
Montant

270

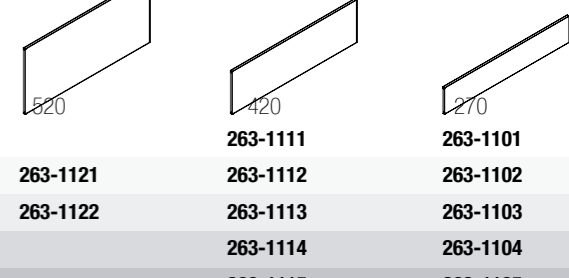

263-1111

263-1112

263-1113

263-1114

263-1115

263-1101

263-1102

263-1103

263-1104

263-1105

iberica

Industrial Laborum

lab integrated systems

sede
Rua Alfredo Cunha, nº155, Loja 34
4450-023 Matosinhos
Portugal

instalações fabris
Sobreiro Torto, Branca - Apt. 187
3854-909 Albergaria-a-Velha
Portugal

delegação comercial
Rua Professor Memâni Cidade 11b
1600-631 Lisboa , Portugal

T +351 234 529 500
F +351 234 529 263

www.industriallaborum.com